

U.S. Department
of Transportation

United States
Coast Guard



Commandant
United States Coast Guard

2100 Second Street S.W.
Coast Guard
Washington, DC 20593-0001
Staff Symbol: (G-NRN)
Phone: 267-0297

COMDTINST M16577.1
APR 21 1993

COMMANDANT INSTRUCTION M16577.1

Subj: DIFFERENTIAL GLOBAL POSITIONING SYSTEM BROADCAST STANDARD

1. PURPOSE. This Differential Global Positioning System (DGPS) Broadcast Standard is intended as reference document. It specifies and describes the parameters and content of the signal which is broadcast for a network of marine radiobeacons. Planned site listings and coverage diagrams are included in the appendices. This standard is intended for general distribution to designers and manufacturers.
2. ACTION. Area and district commanders, commanders of maintenance and logistics commands, and unit commanding officers shall comply with the terms set forth by this instruction.

/s/ W. J. ECKER
Chief, Office of Navigation Safety
and Waterway Services

Encl: (2) Coverage Diagrams
(1) Broadcast Site Listings

PREFACE

This standard is intended for unrestricted public release and distribution. All inquiries pertaining to this standard should be addressed as follows:

Commandant (G-NRN-2)
U.S. Coast Guard Headquarters
2100 Second Street, S.W.
Washington, D.C. 20593
Tel: (202) 267-0298

It is believed that this standard is in full agreement with RTCM SC104 (Version 2.1), however in the event of any discrepancies between these documents, this standard shall take precedence.

TABLE OF CONTENTS

CHAPTER 1. INTRODUCTION	1-1
A. Purpose	1-1
B. Scope	1-1
C. Revisions	1-2
CHAPTER 2. SIGNAL FORMAT	2-1
A. General	2-1
B. Message Types	2-1
C. Message Header	2-1
D. Type 3 Message	2-2
E. Type 5 Message	2-2
F. Type 7 Message	2-3
G. Type 9 Message	2-3
H. Type 16 Message	2-5
I. Message Scheduling	2-6
J. Failure/Default Mode	2-8
CHAPTER 3. BROADCAST CHARACTERISTICS	3-1
A. Marine Radiobeacon Frequency Band	3-1
B. Modulation	3-1
C. General Parameters	3-1
D. Signal Spectrum	3-2
E. Protection Ratios	3-3
F. Signal Strength & Reception	3-5
G. Atmospheric Noise Performance	3-7
H. Coding	3-7
CHAPTER 4. - SYSTEM PERFORMANCE	4-1
A. Accuracy	4-1
B. Availability	4-1
C. Integrity	4-3
D. Reliability	4-4
E. Alarm Mechanisms	4-5
F. Application of Integrity Messages	4-5

CHAPTER 5. - COVERAGE	5-1
A. Policy	5-1
B. Diagrams	5-1
C. Broadcast Site Listing's	5-2
D. Assignment of Reference Station ID Numbers	5-2
E. Information Updates	5-2
CHAPTER 6. - MARINE RADIOBEACON SELECTION & USAGE	6-1
A. General	6-1
B. Satisfactory Broadcast	6-1
C. Extended Broadcast Usage	6-2
D. PRC Time Out Limit	6-2
E. Summary	6-2
APPENDIX 1. - GLOSSARY	A1-1
A. Acronyms	A1-2
B. Definitions	A1-3
ENCLOSURE (1) - Site Listings	
ENCLOSURE (2) - Coverage Diagrams	

CHAPTER 1. INTRODUCTION

A. PURPOSE

1. The DGPS Broadcast Standard is intended as a reference document which specifies the format, information content, modulation parameters, coverage area, and use of the signal which is broadcast from the network of marine radiobeacons which constitute the USCG DGPS Navigation Service. Additionally, this standard specifies the system performance which can be achieved in conjunction with the proper user equipment. This standard is applicable to all broadcasts which are declared operational. Crucial performance and functional elements which are required of the user equipment suite are addressed throughout this document. A document which more specifically addresses user equipment performance requirements will be issued under a separate cover. This standard is intended for general distribution to designers, manufacturers, and users.

B. SCOPE

1. The DGPS Navigation Service augments the Navstar Global Positioning System by providing localized pseudorange correction factors and ancillary information which are broadcast over selected marine radiobeacons. The DGPS Service will provide the mariner with the most accurate navigation system to date in all critical harbor and harbor approach areas. It is the first system which will meet the 8-20 meter (2drms) accuracy requirement called for in the Federal Radionavigation Plan. With the full satellite constellation in place ($HDOP < 2.3$), the accuracy of the DGPS Service will be better than 10 meters (2drms) in all coverage areas. The accuracy will be better than 3 meters (2drms) throughout the most critical constricted waterways through the use of more closely situated reference stations.
2. The user receives system status and quality updates on a continuous basis. Since the DGPS Reference Station utilizes a NAD 83 geodetic monument the position which is displayed by the user equipment suite will also be in the NAD 83 Datum when operating in the differential mode. The DGPS Service not only enhances the accuracy of the Standard Positioning System (SPS), but also provides a real time integrity check. Differential GPS reduces the integrity check interval from on the order of several hours to a matter of seconds. The substantial integrity enhancement of Differential GPS is even of more value to waterway safety than its accuracy enhancement. Under certain circumstances it is also able to utilize certain satellites which are unusable for non-differential GPS.
3. A conceptual overview of the DGPS Navigation Service is illustrated in Figure 1.

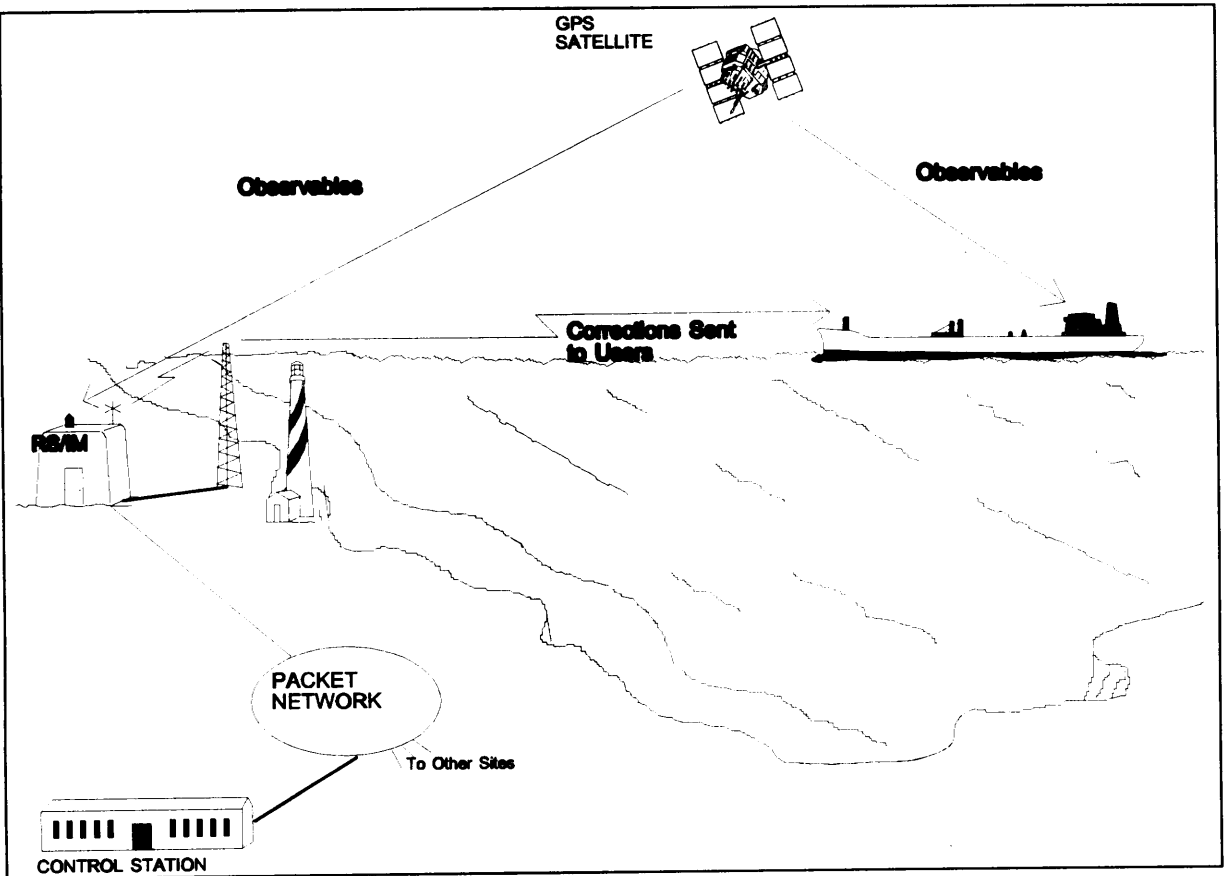

Figure 1. DGPS System Elements

In the network there are two control centers, one for each coast, which continuously poll the monitor and reference stations. Each integrity monitor is co-located with its associated reference station in order to monitor the status and the integrity of the broadcast. The two control centers survey the status of the system and in case of technical difficulty will either resolve the problem through remote means or immediately dispatch technicians to the affected site. As explained in Section 6.A., only the user equipment suite can truly act as the coverage monitor for a given user.

C. REVISIONS

1. With the exception of the data contained in the enclosures, any changes to this standard will result in the release of a revised version. Updates to the information contained in the subject enclosures can be obtained at any time through the vehicle described in 5.E. Within the parameters set forth by this standard the DGPS Program Manager may release revised versions of the enclosures to this standard as deemed necessary.

CHAPTER 2. SIGNAL FORMAT

A. GENERAL

1. The broadcast data consists of a selected subset of the message types contained in the RTCM Special Committee No. 104, Version 2.1, Recommended Standards for Differential Navstar GPS Service, herein referred to as "RTCM SC104 (Version 2.1)". All selected message types are broadcast in the format of RTCM SC104 (Version 2.1) except as otherwise noted.

B. MESSAGE TYPES

1. RTCM SC104 (Version 2.1) Message Types which will be broadcast consist of Types 3, 5, 6, 7, 9, and 16. When the presently reserved, but undefined, Type 15 Message (atmospheric parameters) is developed it will most likely be broadcast by the USCG Differential GPS Service. Stated performance of the system is only applicable for user equipment suites which fully incorporate all of the aforementioned message types. If Selective Availability were permanently discontinued use of the Type 1 Message may be revisited as it is able to utilize a less expensive frequency source, hence user equipment suites should retain the ability to process it. RTCM SC104 (Version 2.1) requires that the service provider further specify the content of several message types. Further description is given for Message Types 5, 7, 9 and 16, along with a complete description of the use of the message header when operating within the DGPS Navigation Service. Unless otherwise noted, all message types are applied in the manner recommended in RTCM SC104 (Version 2.1).

C. MESSAGE HEADER

1. In the DGPS Navigation Service the "Station Health Field" (bits 22-24) in the message header for the Type 9 Message (9-1 and 9-3) requires a special interpretation. Table 1 delineates the pertinent meaning of the bits in this field. The enhancements to the UDRE (user differential range error) resolution will provide a substantial added value to the system. For the Type 9-3 Message, the UDRE scale factor is determined by the satellite with the largest UDRE value. If an unhealthy or unmonitored condition exists, the UDRE Scale Factor reverts back to a value of unity.

D. TYPE 3 MESSAGE

1. Two reference stations will be located at each broadcast site. At any given time one will be on air and the other will serve as a "hot standby". Since each reference station will have its own antenna, the coordinates which are broadcast in the Type 3 Message may change from time to time. The Type 3 Message will contain NAD 83 Coordinates since this system is the only one in North America which can take advantage of the centimeter resolution provided in this message.

TABLE 1. MSG. HEADER STATION HEALTH FIELD

CODE	INDICATION
111	UNHEALTHY BROADCAST
110	UNMONITORED BROADCAST
101	UDRE SCALE FACTOR = 0.10
100	UDRE SCALE FACTOR = 0.20
011	UDRE SCALE FACTOR = 0.30
010	UDRE SCALE FACTOR = 0.50
001	UDRE SCALE FACTOR = 0.75
000	UDRE SCALE FACTOR = 1.00

E. TYPE 5 MESSAGE

1. The sole use of this message type will be to notify the user equipment suite that a satellite which is deemed unhealthy by its current navigation message is usable for DGPS navigation. This is accomplished by the setting of the "Health Enable Function" in the Type 5 Message by the reference station in order to indicate this condition. An example of this situation is a slowly drifting satellite clock which may render a satellite unhealthy for GPS use, but would be correctable by the reference station for DGPS use. The user equipment suite should not use an unhealthy satellite unless a Type 5 Message allowing the use of an unhealthy satellite was received within the last thirty minutes. If the most recent Type 5 Message received does not indicate that an unhealthy satellite can be utilized, than the use of that satellite should be discontinued if it were being used (i.e. via a previous Type 5 Message). Type 17 Messages will not be issued in conjunction with the "navigation data warning" as allotted for in RTCM SC104 (Version 2.1).

F. TYPE 7 MESSAGE

1. A Type 7 Message which is broadcast from a marine radiobeacon will contain information for two or three adjacent marine radiobeacons which are part of the DGPS Network in addition to itself. Marine radiobeacons in certain locations, including a substantial number in the Great Lakes and several coastal harbors, will contain information on three surrounding marine radiobeacons in addition to the beacon from which the broadcast is received while the remaining sites will contain information on two surrounding beacons. The user equipment suite should update its internal almanac on an immediate basis as new information is received. Nonvolatile memory should be employed to store the internal almanac. When a broadcast becomes unhealthy or unmonitored in a DGPS Service Area the Type 7 Messages which include the inflicted radiobeacon will be set to indicate the subject condition and, upon receiving the next Type 7 Message, the user's equipment suite should immediately update its internal almanac. When a radiobeacon becomes unhealthy or unmonitored, the user equipment suite is immediately notified by means of the station health status indicator contained in the second word of the universal message header. The user should be able to view the contents of the current Type 7 Message in order to obtain information on coverage areas which may soon be entered. For Type 7 Message usage in the selection of the appropriate radiobeacon see Section 6.

G. TYPE 9 MESSAGE

1. Due to the advantages of greater impulse noise immunity, lower latency (the latter is illustrated in Figure 2), and a timely alarm capability, the Type 9 Message has been selected over the Type 1 Message. The Type 9 Message will serve as the exclusive message type for broadcasting pseudorange corrections.
2. The first method which will be utilized to broadcast PRC's (Pseudorange Corrections) is based upon "Three-Satellite Type 9 Messages" which are denoted as "Type 9-3" Messages. In this method all satellites for which corrections are broadcast are assigned to either three satellite Type 9 Messages or to a remainder message of either one or two satellites. For example, the pseudorange corrections for eight satellites would consist of three Type 9 Messages, two with 3 satellites and one with two satellites. An equal number of corrections are broadcast for each satellite. In order to make optimum use of the UDRE Scale Factor in the message header, satellites will be grouped in messages by their UDRE values. This method will employ a transmission rate of 200bps and represents a minimum of a forty percent reduction in message loss as compared to a Type 1 Message under high noise conditions broadcast at the same bit rate. The relative latency of the different PRC message types is illustrated in Figure 2 - note that since the corrections can be applied as soon as the parity is verified for the words which contain a given correction the latencies in Figure 2 are the maximum latencies. PRC accuracy is for the most part a function of the latency of the Range Rate Correction (RRC) since it is the only PRC component in which the error is a function of time. The error of the PRC(t_0) term is fixed at

the time of measurement and any errors that result from its propagation are a function of RRC accuracy. Figure 3 illustrates an additional advantage of the Type 9 Message - the phasing of the PRCs. When the latency for certain satellites is nearing its maximum the latency for others is very low. This provides a built-in immunity factor to high pseudorange accelerations on one or more satellites. The potential to weight pseudoranges on the basis of latency is readily apparent and should prove most beneficial to the positioning user. The 200bps transmission rate will generally be used in constricted waterways and VTS Areas of Responsibility - for VTS areas the 200bps rate will assure a very accurate continuous velocity measurement capability. An extremely high level of impulse noise immunity is achieved by this method at the expense of slightly reduced range for the same effective radiated power in low noise conditions. This is taken into account by the use of a higher field intensity (100uV/m vs. 75uV/m).

3. The second method used to broadcast pseudorange corrections is essentially the same as method 1, the only differences being the use of a 100bps transmission rate and a minimum field intensity of 75uV/m.
4. The third method of broadcasting pseudorange corrections is to broadcast individual Type 9 Messages for each satellite at a transmission rate of 50bps. This message is referred to as the "Single Satellite Type 9 Message" and is denoted in this document as the "Type 9-1 Message". A high level of impulse noise immunity is achieved by this technique which will extend the effective range of the broadcast. This method will be utilized only if Selective Availability were permanently discontinued. Lower transmission rates than 50bps could not be used in order to meet the time to alarm requirement due to the length of the PRC Messages. The added latency would not be a factor due to the absence of SA. An equal number of corrections are broadcast for all satellites regardless of their pseudorange rates or accelerations.

Table 2. PRC Message Broadcast Parameters

METHOD	MESSAGE TYPE	DATA RATE	TRAN. RATE
1	TYPE 9-3	200BPS	200BPS
2	TYPE 9-3	100BPS	100BPS
3*	TYPE 9-1	50BPS	50BPS

* authorized for use only if SA were permanently discontinued

5. Since each Type 9 Message contains the freshest possible corrections, the corrections contained in each and every Type 9 Message are computed at different times (i.e. computed at the latest possible time before broadcast). The user equipment suite can mix corrections which may have been computed up to 30 seconds apart, thus the reference station must utilize a highly stable frequency source, within one part in 10¹¹ (30 second Allan Variance). Any unmodeled adjustments to the reference station clock will be kept to less than 1ns in any 60 second period. The use of a highly stable frequency reference and a tightly controlled clock provides the

additional benefit of allowing corrections for each satellite to be applied as they are received, as long as the parity for both of the words which contain a given correction is verified - this capability should be implemented for the Type 9 Message in all user equipment suites. Corrections will not be projected forward in time by the Reference Station. Generally, the Reference Station Clock will be within 100ns of GPS time. Clock stability is of a far greater priority than absolute time accuracy since PRC's are generated relative to each other for a given Reference Station.

6. The shorter message length and greater frequency of preambles provided by the Type 9 Message result in a substantially improved impulse noise performance as compared with the Type 1 Message. The higher rate of preambles allows a much faster re-synchronization, especially during high noise periods. As previously discussed, even in low noise conditions the Type 9-3 Message provides a lower latency than the Type 1 Message, making it advantageous when operating with a low data rate as well as in high noise environments. This is especially useful since the position error growth due to latency is non-linear.
7. Due to sudden pseudorange accelerations it was decided that basing either method on pseudorange velocity or acceleration would prove to be overly cumbersome and of considerable operational risk. Hence, an equal number of corrections will be broadcast for all satellites regardless of the method employed to broadcast corrections.
8. If a satellite suddenly becomes unhealthy when in use by a given reference station the $PRC(t_0)$ and the RRC are set to predefined values as delineated in RTCM SC104 (Version 2.1) which designate this condition.

H. TYPE 16 MESSAGE

1. The Type 16 message will be utilized as a timely supplement to the notice to mariners regarding information on the status of the local DGPS service which is not provided in other message types. Additionally, the Type 16 Message may provide limited information on service outages in adjacent coverage areas or planned outages for scheduled maintenance at any broadcast site. In order to keep data link loading to a minimum, Type 16 Messages will contain only system information which is crucial to the safety of navigation. Any broadcast of the Type 16 Message will not exceed 5.1 seconds; at 100bps this translates into 17 words which allows 45 characters after accounting for the message header. The Type 16 Message is not intended to act as a substitute for the notice to mariners, even as it pertains to DGPS information. Type 16 Messages will be utilized to alert the user of an outage condition for which a broadcast in an adjacent coverage area may be unhealthy, unmonitored, or unavailable. This information would be useful to the mariner whom is planning a transit through an afflicted area or whose equipment suite is presently incapable of automatic selection from the beacon almanac. Further details of an outage condition can be derived from the Type 7 Message for planning purposes.

I. MESSAGE SCHEDULING

1. In general, the data stream will consist mainly of message types 3, 7, & 9 as the broadcast of message types 5 and 16 will be rather infrequent. Due to the advent of continuous tracking receivers the Type 2 Message is no longer required and its use would only serve to increase the latency of the broadcast. For each new Issue of Data (IOD) there will be a 90 second delay before the broadcast pseudorange corrections are computed with the new IOD. Ninety seconds should be more than adequate for a continuously tracking DGPS receiver, as it will be able to instantaneously read the navigation messages as they are broadcast from each satellite. Sequencing Receivers are not to be used for navigational purposes within the USCG Differential GPS Navigation Service. Any shading of a satellite at IOD, such as passing under a bridge, are compensated for by the ninety second delay. This method of handling a new IOD requires the user equipment suite to store both the new and the old IOD for the subject period. No ancillary messages will be broadcast within 90 seconds of each other under any circumstances.
 - a. Type 3 Message: Type 3 Messages will be broadcast at fifteen and forty-five minutes past the hour.
 - b. Type 5 Message: If an unhealthy satellite is deemed usable for DGPS, a Type 5 Message will be broadcast at five minutes past the hour and every fifteen minutes thereafter. If an unhealthy satellite which was deemed usable is later deemed unusable the reference station will no longer broadcast corrections for the subject satellite.
 - c. Type 7 Message: A routine Type 7 Message will be broadcast at ten minute intervals beginning at seven minutes past the hour. Type 7 Messages will be updated and broadcast within two minutes if the status of a beacon changes for which they contain information. This will aid the user equipment suite in its choice of the proper beacon.

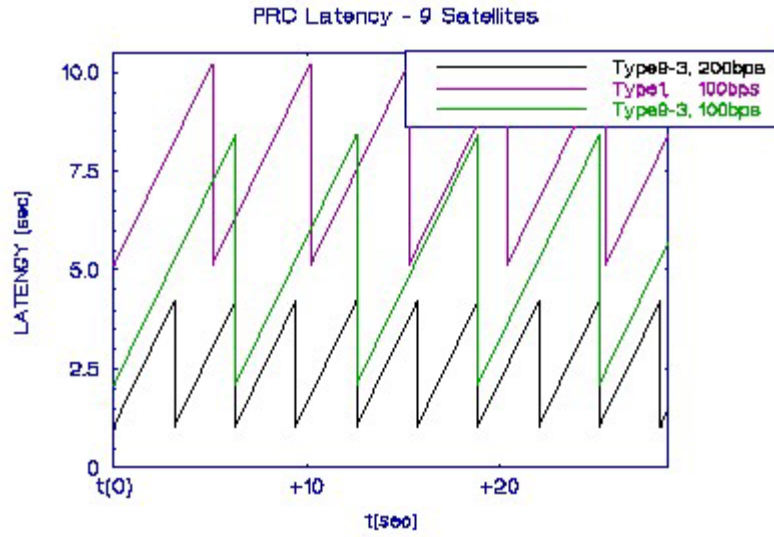

Figure 2. PRC Latency-Individual SV

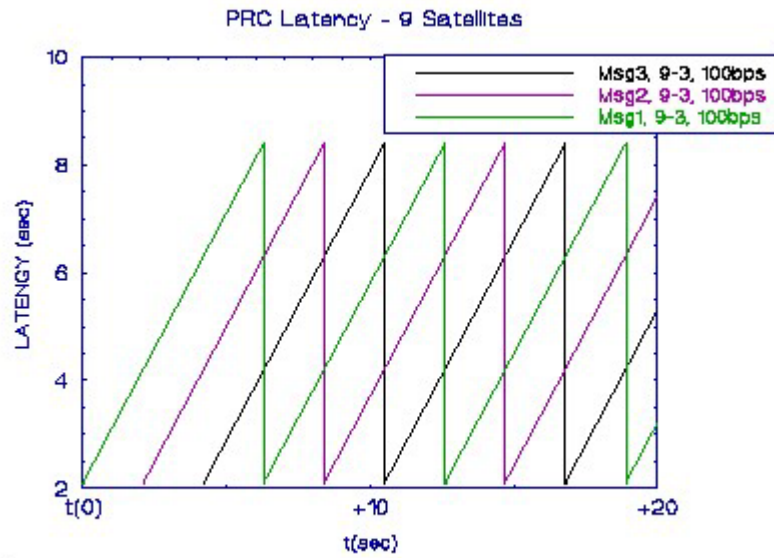

Figure 3. Type 9-3 Message Phasing

- d. Type 9 Message: Corrections will be broadcast only for satellites at an elevation angle of 7.5 degrees or higher through use of the Type 9 Message. The official GPS coverage which is provided is based on elevation angles of ten degrees or higher. Satellites at elevation angles lower than 7.5 degrees are adversely effected by spatial decorrelation, multipath, and minimal processing time between acquisition and actual use. The level of 7.5 degrees is identical to that recommended by RTCA Special Committee 159. Corrections for a maximum of nine satellites will be broadcast. If more than nine satellites are above a 7.5 degree elevation angle, a situation which occurs less than one percent of the time, then corrections are broadcast for the nine satellites with the highest elevation angles. If the choice is between two satellites with elevation angles which are greater than 7.5 degrees, but within two degrees, the descending satellite is chosen. Positioning users of the system who are interested in achieving the highest accuracy level possible should use a higher mask angle in order to avoid the higher atmospheric effects associated with low elevation satellites. When a reference station drops a satellite it will broadcast an indication to user equipment suite per 4.E.1 to stop applying corrections for that satellite to its navigation solution.

- e. Type 16 Message: This message type will be broadcast as deemed necessary but within strict limits. Type 16 Messages will not be broadcast for a period of at least ninety seconds preceding or following a Type 3, 5, or 7 Message and the interval between successive Type 16 Messages will be no less than three minutes.

J. FAILURE/DEFAULT MODE

- 1. A failure represents the absence of either pseudorange corrections in the broadcast stream or the absence of any message transmission at all. If a radiobeacon can no longer transmit any information, this condition will be broadcast to the user as a Type 16 Message via adjacent marine radiobeacons. Shall any of the aforementioned conditions occur, an updated Type 7 Message for all surrounding marine radiobeacons will be automatically generated and immediately broadcast by the appropriate marine radiobeacons in the area. If the reference receiver can no longer generate pseudorange corrections, Type 6 Messages will be broadcast in which the message header will be set to indicate an unhealthy condition.

- 2. In the case where the reference receiver can not generate Type 6 Messages, a single tone will be broadcast. Modulator failures may result in the broadcast of alternating ones and zeros, a single tone, or no output at all. As a modulator failure could occur at any time, it is imperative that the user equipment suite be capable of detecting the absence of RTCM messages containing pseudorange corrections in the data stream and if available tune to a different marine radiobeacon in advance of the "PRC Time Out Limit" (see Section 6D). It may be matter of minutes before the standby reference station is put on line. The broadcast of alternating ones and zeros should not cause any false acquisitions since the subject broadcast will be listed as unhealthy by the Type 7 Message. Should it be anticipated that an out of tolerance condition will continue for more than two hours a "Notice To Mariners" will also be issued. Refer to Section 5.E. for obtaining 24 hour on-line operational information on the DGPS service.

CHAPTER 3. BROADCAST CHARACTERISTICS

A. MARINE RADIOBEACON FREQUENCY BAND

1. DGPS Transmissions are broadcast in the 285 to 325 KHz band which is allocated for maritime radionavigation (radiobeacons). Marine radiobeacons which are selected for DGPS Service will simultaneously broadcast DGPS and radiodirection finding (rdf) signals. From a marine radiobeacon the DGPS transmissions may be broadcast either on the main carrier or in very limited circumstances, on a dual carrier. Radiodirection finders will only utilize the main carrier and the subcarrier id tone. When a dual carrier is utilized it will be 500 Hz above the main carrier. The main carriers for all marine radiobeacons are spaced at 1 KHz intervals and are placed on multiples of 1 KHz (e.g., 318.0 KHz as opposed to 318.5 KHz). As explained in Section 3.E. all 200bps transmissions will be assigned to channels which are centered at $283\text{KHz} + n(2 \text{ KHz})$ where n is an integer having values of 1 through 21.

B. MODULATION

1. The DGPS Broadcast will utilize Minimum Shift Keying (MSK) Modulation, a special case of Continuous Phase Frequency Shift Keying (CPFSK). The "continuous phase" aspect minimizes the spectral content outside of the Nyquist Bandwidth while the use of quadrature components raises the bandwidth efficiency to that of Quadrature Phase Shift Keying (QPSK). A "binary 0" is represented by a linear 90 degree phase retard relative to the carrier phase in one bit duration and a "binary 1" is represented by a linear 90 degree phase advance relative to the phase of the carrier in one bit duration. The frequency separation between the antipodal binary tones which are utilized is equal to one-half of the transmission rate. The modulation rates chosen assure phase continuity at bit transitions.

C. GENERAL PARAMETERS

1. Frequency Tolerance: The carrier shall maintain a frequency accuracy within plus or minus 6ppm. (e.g., 2Hz for a 325KHz broadcast)
2. Phase Noise: The SSB Phase Noise of each tone shall be less than -80dB/Hz at an offset of 10Hz.
3. Spurious Outputs: All spurious outputs shall be less than -60 dBc.
4. Synchronization Type: Synchronous
5. PRC Latency: The average latency of the corrections at broadcast shall be less than 0.25 seconds.

5. PRC I-aten CV: The average latency of the corrections at broadcast shall be less than 0.25 seconds.

D. SIGNAL SPECTRUM

1. The selected transmission rates for the USCG DGPS Navigation Service are 100 and 200 bits per second (bps) as illustrated in Table 2. If Selective Availability were permanently discontinued a 50bps transmission rate maybe employed utilizing Type 9-1 messages, being constrained at the lower transmission rate by the "time to alarm" requirement The short Type 9-1 Message will allow the time to alarm requirement to be met with a minimum bit rate of 50bps. Generally the 200bps transmission rate will be reserved for selected critical waterways. Adiscwsed in section 2G, all data S rates of 100bps and 200bps will utilize the Type 9-3 Message. The tradeoff presented here is that higher transmission rates are more subject to message loss induced by Gaussian Noise but achieve a higher message throughput in impulse noise conditions. The 99 percent power containment bandwidth of the MSK modulated signal is equal to 1.17 times the transmission rate, and the half power bandwidth is given by 0.59 times the transmission rate. Figure 4 frustrates the spectrum of a main carrier DGPS broadcast at transmission rates of 100 and 200bps. The spectrum when a DGPS Broadcast is modulated at the same transmission rates, but on a dual carrier which is set at 6 dB higher, is illustrated in Figure 5. The main carrier is used exclusively for direction finding purposes. Six dB represents a factor of four in power and factor of two in field intensity. The latter method provides for a high degree of spectrum conservation, but at the cost of higher capacity transmitting and auxiliary equipment. As can be seen in each of the subject figures, all broadcast scenarios contain a subcarrier id tone at 1020 Hz above the main

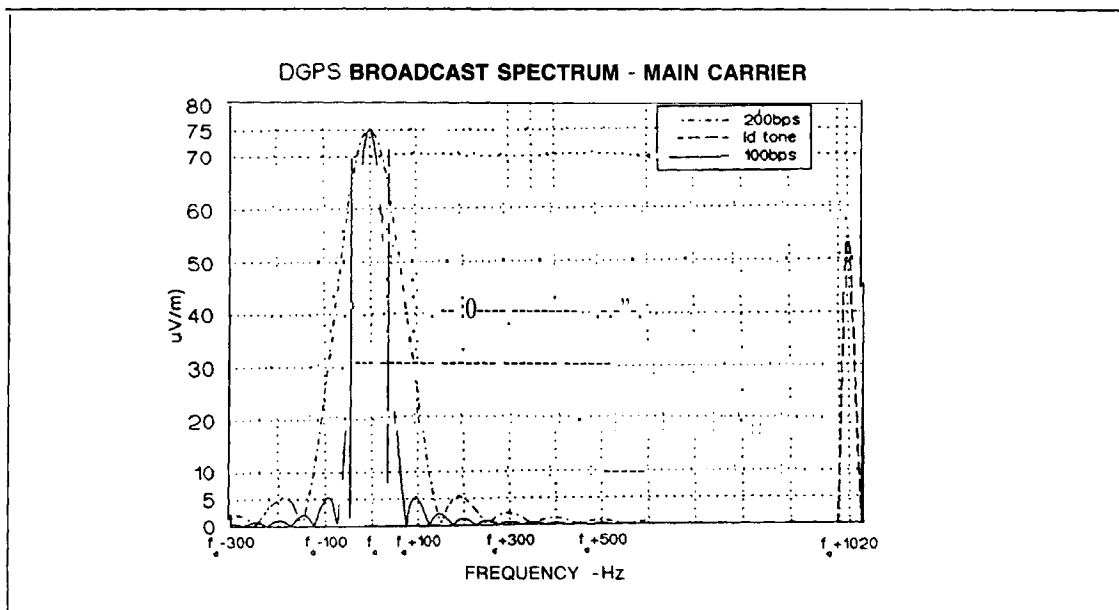

Figure 4.

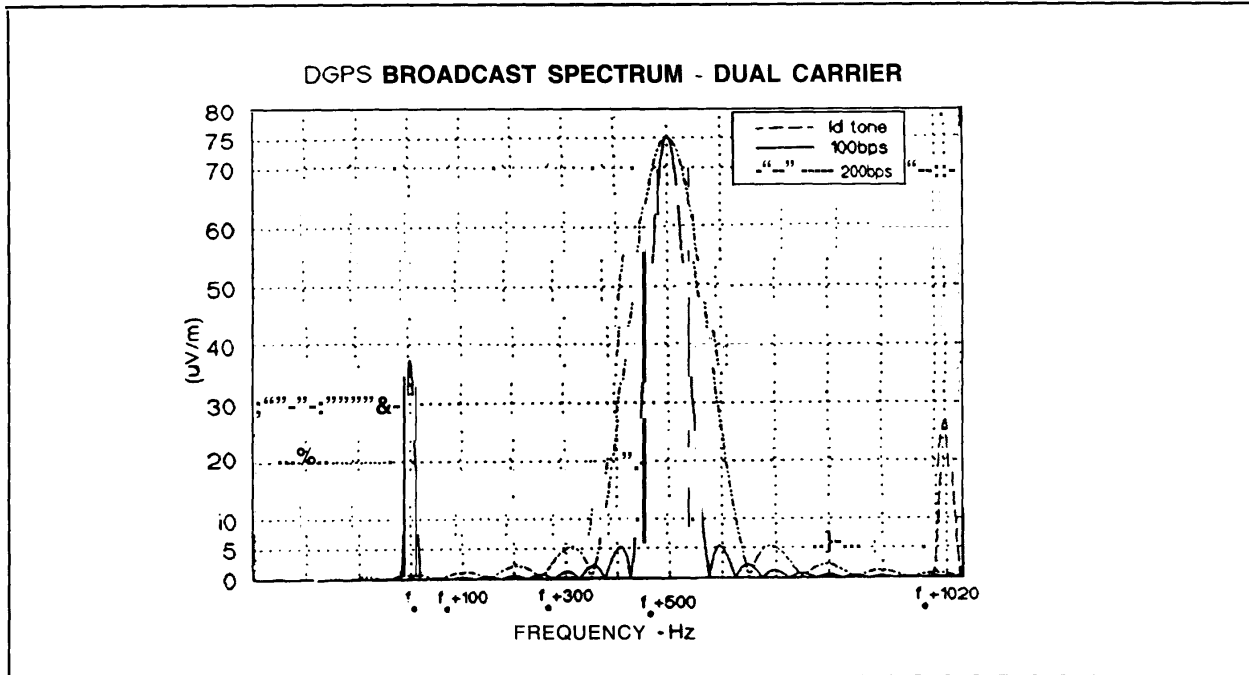

Figure 5.

carrier. This tone is broadcast solely for the use of DF Receivers which mix it with the main carrier to create a signal which is AM Modulated at a level of 70%. As observed in the subject figures, the subcarrier id tone is broadcast at a level which is 3dB below the main carrier. Due to the desequencing of sequenced beacons and the lower concentration of radiobeacons in general strong consideration is being given at this time to the discontinuance of the id tone for most DGPS Broadcasts as this will reduce spectral congestion, enhance the effectiveness of receiver blanking circuitry, allow more useable power to be transmitted, and allow the use of highly efficient nonlinear transmitters. For a given DGPS Broadcast the id tone may or may not be present.

2. Due to the planned extensive reduction in the number of purely direction finding beacons by the year 2000 it is anticipated that the use of dual carrier DGPS broadcasts will no longer be required. Even before the year 2000 dual carrier broadcasts will not be widely used.

E. PROTECTION RATIOS

1. The protection ratios which are relevant to the reception of DGPS Broadcasts are given in Table 3. Note that the "frequency separation" denotes the separation between each carrier (main, dual, or id tone) which is transmitted from broadcast sites other than that for the "wanted" signal. This method follows the Ew (European Maritime Area) convention (where Radiobeacon transmissions contain

Furthermore the IFRB (International Frequency Registration Board) has recommended that DGPS Transmissions be treated as independent as opposed to composite transmissions when applying protection ratios. Presently, all radiobeacon protection ratios are computed for the main carrier with the effect of the subcarrier inherent in its determination (i.e., the composite method). Since up to three carriers in two different formats will now be broadcast, the previous method would be overly cumbersome and not explicative in nature. No change is being implemented at this time for computing the protection of RDF carriers (which is done in a composite form), even those with DGPS information directly on them (i.e., not dual carriers). The existing radiobeacon to radiobeacon specifications are far more stringent than those being proposed with the exception of the zero Hertz (co-channel) separation case. The protection ratios presented in Table 3 set the minimum levels required and any future changes in the protection ratios will only result in a more hospitable operating environment. All receiver designs must work in the environment defined by these protection ratios applied in conjunction with the spectra presented in Figures 6 and 7. The protection ratios presented in Table 3 were derived on the basis of a maximum transmission rate of 200bps. All 200bps transmissions are centered at 283KHz + n(2KHz) where n is an integer having values obandlimiting/filtering of the transmitted signal is utilized since the realization of ideal filters would be difficult to approach and thus intersymbol interference becomes a concern.

TABLE 3.

DGPS APPLICABLE PROTECTION RATIOS

FREQUENCY SEPARATION (KHz)	WANTED:	DGPS	DGPS	DGPS
	INTERFERING:	RBN (RDF)	RBN (id)	DGPS
0.0		15dB	15B	15dB
0.5		-25dB	-25dB	-22dB
1.0		-45dB	-45dB	-36dB
1.5		-50dB	-50dB	-42dB
2.0		-55dB	-55dB	-47dB

2. The main emphasis in the determination of the Protection Ratios was to minimize the cost of the user equipment and to allow effective impulse processing within the framework of the existing marine radiobeacon network. The protection ratios which cover the protection of Marine Radiobeacons from DGPS transmissions are identical to those for interference from other beacons and are covered by an existing international agreement (which may be replaced by a North American Agreement similar in nature to that of the EMA agreement). The Normalized Spectral Densities shown in Figures 6 and 7 illustrate the relative spectral content of an MSK

Transmission and are useful in computing the amount of interference which can fall within the processing bandwidth of the receiver. To accommodate receiver designs with wide bandwidth burst detection and IF (intermediate frequency) circuitry, as they possess a superior impulse processing capability, a 4KHz (i.e. plus or minus 2KHz) bandwidth was considered in the determination of the values of Table 3. DGPS Broadcasts which are designated as prototypes are exempt from the subject protection ratios only in their role as the "wanted" signal. They must adhere to the Protection Ratios listed in Table 3. in their classification as interfering signals.

3. A DGPS Broadcast is protected by the protection ratios of Table 3 at the minimum "wanted signal" field strength of 75uV/m for its full advertised coverage range.

F. SIGNAL STRENGTH & RECEPTION

1. During normal operation the minimum field strength of the DGPS broadcast signal will be 75 microvolts per meter in the various coverage areas. For broadcasts with a transmission rate of 200bps the minimum field strength will be 100 microvolts per meter. The minimum field strength is applicable only in areas where no other broadcast provides the specified minimum field strength. Field strengths are specified at five feet above ground level (see Appendix 1). The range of a broadcast is specified as the distance along the path of minimum attenuation through a given coverage area that the signal travels before reaching its specified minimum field strength. Due to land masses in various coverage areas the advertised range may not be always representative of the coverage provided in all coverage areas surrounding a given broadcast, however those areas have an additional broadcast which serves as the primary beacon for that area. A good example of this is the Ft. Gratiot Site on Lake Huron as it achieves its advertised 140mi range over Lake Huron but would not, for example, always cover waterways such as the Detroit River to the south. However, the Belle Isle Broadcast Site was situated to provide the primary coverage for this area. As discussed in Section 6, the advertised range of a broadcast ifor selection purposes only. It is the user equipment suite, utilizing which determines the suitability of the broadcast for a user in a given place maximum field strength occurs in practice when a vessel passes within several hundrebroadcast site and may approach 150mV/m. In general, to cope with conditions, the user may need to utilize a minimum field strength which c10uV/m in systematic problem conditions. This level may still providdepending on the level and nature of the atmospheric noise which is presenvariations result in broadcasts which may greatly exceed theithroughout most of the year since their availability at the user was calculatrangle of conditions expected throughout the year. In the MF Banapproximation between distance and field strength proves to be very accup to several hundred miles. For example, if the field strength at a digiven beacon is 100uV/m then at 100mi from the same beacon the field strength would be200uV/m.

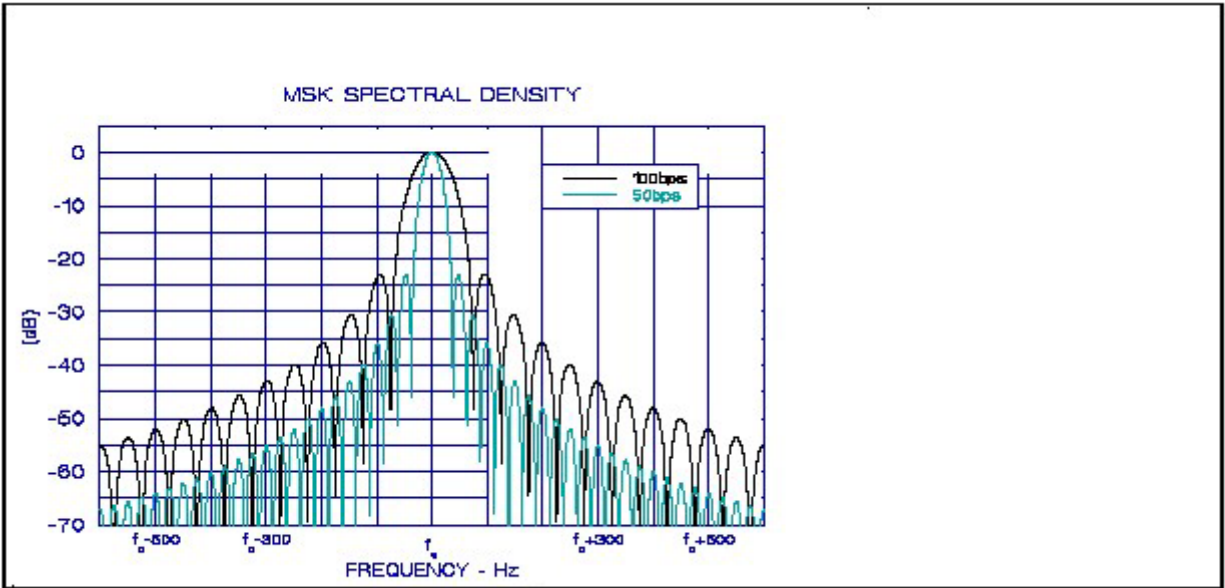

Figure 6

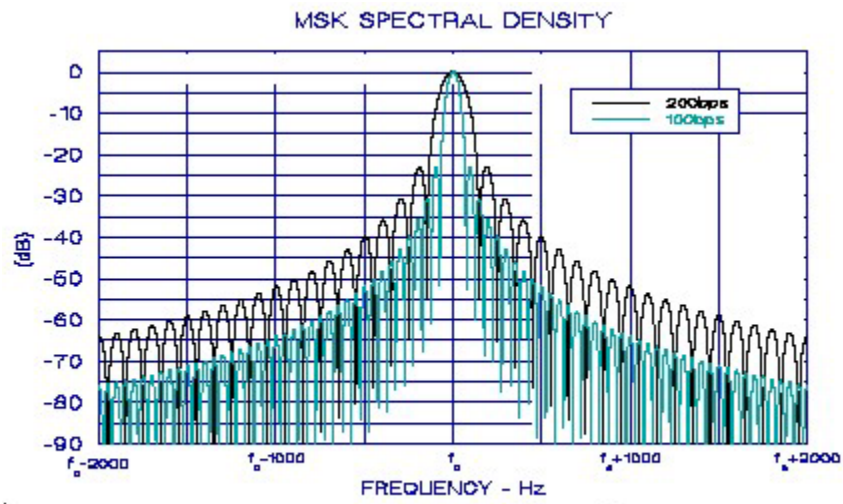

Figure 7

G. ATMOSPHERIC NOISE PERFORMANCE

1. For use in navigation (as opposed to positioning) an MSK Beacon Receiver should achieve a bit error rate of less than 10 under the three conditions listed below. Except for Condition 3, in -3 which the MSK Signal is first applied, the MSK Signal should be acquired in less than 20 seconds.
 - a. An MSK signal is incident upon the antenna at a level of 75uV/m and with an SNR of 7dB in the 99% power containment bandwidth of the MSK signal.
 - b. An MSK signal of 75uV/m is incident upon the antenna along with a pulse train with an amplitude of 500mV/m, a period of 0.5 milli-seconds, a pulse width of 20us, and with rise and fall times (90%) of less than 50ns.
 - c. An MSK signal of 75uV/m is incident upon the antenna along with a pulse train with an amplitude of 15 V/m, a period of 1.5 milli-seconds, a pulse width of 20us, and with rise and fall times (90%) of less than 50ns.
2. The stated performance should be achieved for all bit rates and in the presence of any two simultaneously present interfering tones incident upon the antenna per Column 3 (RDF Interference) of Table 3. A more comprehensive document covering recommended MSK Receiver Performance will be released as a COMDTPUB (Commandant Publication).

H. CODING

1. For increased performance in certain circumstances, further consideration may be given to the implementation of a coding scheme such as Reed-Soloman with Erasure. Coded transmissions would have a 200bps transmission rate and approximately a 100bps data rate.
2. As discussed earlier the 100bps data rate is used exclusively for Type 9-3 pseudorange correction messages. Such coding may receive future consideration for implementation on selected radiobeacons which provide redundant coverage for selected areas. Adjacent broadcast(s) may provide uncoded DGPS coverage for the general user within the coverage area of the coded broadcast. It is anticipated that only the equipment suites carried by a limited class of vessels which traverse certain waterways may be required to have a decoding capability if coding were ever implemented. Though coding provides a significant error reduction in Gaussian and impulse noise conditions, it introduces a considerable latency factor which is undesirable in time sensitive applications such as navigation or real time high accuracy positioning. Coding also delays the reception of alarms by the user. Though it is anticipated that coding will generally not be beneficial, certain circumstances may benefit through its use. In general for the MF band, coding extends the range of a broadcast at the expense of availability and thus is mainly of interest to positioning services.

CHAPTER 4. SYSTEM PERFORMANCE

A. ACCURACY

1. With the full satellite constellation in place (HDOP <2.3) the position accuracy of the USCG DGPS Service will be within 10 meters (2drms) in all specified coverage areas. As the DGPS Reference Station utilizes a geodetic monument which is referenced to the NAD 83 Coordinate System, the user's differentially-determined position solution is inherently transformed into the NAD 83 Coordinate System. The user equipment suite need not perform any datum conversion from WGS-84 when operating within the USCG Differential GPS Navigation Service and working with NAD 83 Charts. Order "B" Geodetic Monuments will be utilized at all broadcast sites.
2. A reasonable approximation for determining the achievable accuracy at a given point is to take the typical error at a short baseline from the reference station (on the order of 0.5 meters), add an additional meter of error for each 150 kilometers of separation from the reference station (broadcast site) and add an additional 1.5 meters of error for the user equipment. Some high-end user sets are achieving pseudorange measurement accuracies of less than 30 centimeters for a given pseudorange in the absence or the abatement of multipath. Hence, one can readily see that for the user with high-end equipment who is within 300 kilometers from a given broadcast the achievable accuracy is better than 3 meters (2drms). The use of the UDRE information which is broadcast will greatly aid the user in locating a given position to within one meter. The UDRE Values, in conjunction with localized user information, can provide the user with a confidence level about the displayed position.
3. The continuous velocity accuracy of the system (i.e., the vessel's speed over ground) will be better than 0.1 knots rms in VTS areas which utilized dependant surveillance.

B. AVAILABILITY

1. Availability for a given broadcast is defined as the percentage of time in a one month period during which a DGPS Broadcast transmits healthy PRCs at its specified output level. The DGPS Navigation Service was designed for, and is operated to, maintain a broadcast availability level which exceeds 99.7%, assuming a complete and healthy satellite constellation is in place (i.e., HDOP<2.3). Any DGPS Area of Coverage (AOC) that falls within a Vessel Traffic Service AOC which utilizes "dependent surveillance" for vessel tracking will maintain a signal availability in the AOC of 99.9%. A signal availability will be higher than a broadcast availability if an AOC is covered by more than one broadcast.

2. The most significant availability specification is the availability at the user which is simply referred to as user availability. It is the most difficult to quantify due to the nature of the atmospheric noise. Quantitative analysis shows that for a given coverage area it lies somewhat higher than 98% but empirical data with the latest MSK Receiver Technology needs to be collected over a period of several years in order to ascertain a more exact number. In that reference stations are generally located in very close proximity to the most critical waterways the user availability in these areas is essentially equal to the broadcast availability and will exceed it if more than one broadcast covers that critical waterway. The value of the DGPS Navigation Semke relative to its user availability level can be assessed, dependant combination of safer and more efficient navigation. on whether at the system is intended as primarily for safer navigation or for a<

3. If the service is intended primarily for safer navigation (*safety enhancement mode*) then the percentage of time that the service is available to the user is strongly correlated with the percentage of reduction in navigation related incidents. In this use DGPS is used as an additional navigational aid - the vessel operates under expected conditions which allow the use of supplemental navigational aids (e.g. piloting, radar...). Substantial environmental and safety of life benefits are realized. Residual economic benefits that result are reduced vessel repair, down time, and

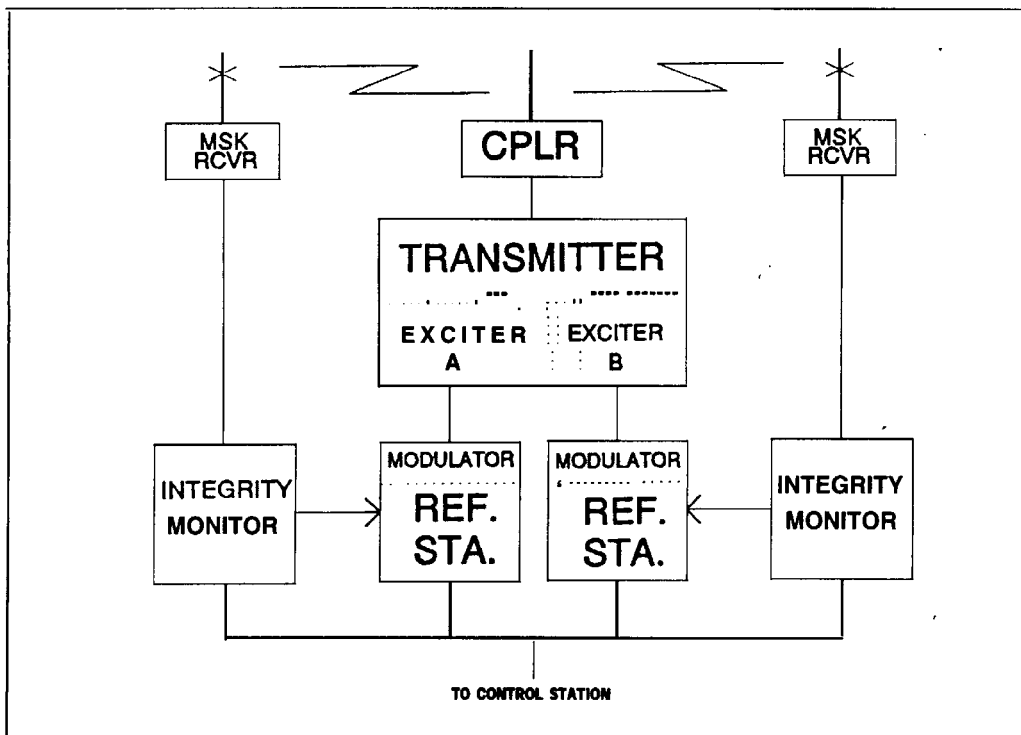

Figure 8. - BROADCAST SITE DIAGRAM

insurance costs. In summary, the level of user benefit in this application is directly proportional to the user availability of the service. In this usage unavailability carries no reduction in the safety level prior to the introduction of DGPS into a given waterway. It is expected that a substantial reduction in the number of vessel casualties due to the sudden loss of visibility will be experienced.

4. DGPS is often referred to as an enabling technology. If the role of the service in a given area is increased waterway efficiency as well as enhanced safety (*safety/efficiency enhancement mode*) then the permissible envelope of operational conditions needs to be expanded, predicated on the robustness of the DGPS Navigation Service. For a given waterway, the degree of the expansion of the operational envelope will depend on the demonstrated level of availability for the constricted areas of that waterway. Where non-hazardous cargoes are concerned the potential for increased efficiency through the use of DGPS is substantial. At worst, the integration of an inertial unit into the user equipment suite would be required to help the vessel navigate through a given maneuver if a sudden outage occurred. Once out of a constricted area other sensors such as radar would be adequate until safe anchorage is reached. In this case a very high user availability is required, on the order of 99.9%, and thus may require an additional DGPS Broadcast in that area. Unavailability can carry a safety penalty if the level of unavailability becomes too high where the envelope of operational conditions is expanded.
5. The phenomena which mainly determine the user availability level of the service in a given AOC are equipment reliability and broadcast link robustness. The use of redundant equipment is utilized in many aspects of the system and several waterways are covered by redundant broadcast sites. The signal strength and structure utilized will overcome the time variant levels of atmospheric noise and thus provide the specified level of availability. Since the Reference Station - Integrity Monitor (RSIM) sets can operate autonomously without regular intervention from the operations center the communication lines have a reduced effect on system availability. Each broadcast site will contain two RSIM sets. Under certain circumstances the switch over between sets will occur automatically, though the health status will then become unhealthy for a short period, and under other circumstances it will require intervention from the control center. The broadcast site configuration is illustrated in Figure 8, not shown are the 4 GPS antennas as each RS and IM has its own GPS antenna.

C. INTEGRITY

1. System Integrity is built upon the foundation of the monitor stations. The monitor station will ensure the integrity of the broadcast PRCs on the pseudorange level as well as provide an additional check on the positional level (overdetermined solution). The process utilized by the integrity monitor is shown in Figure 9.
2. The user equipment suite plays a significant role in assuring that the integrity of the system is preserved. It should be capable of automatically selecting the appropriate radiobeacon as discussed in Section 6. A continuously tracking receiver with nine or more parallel channels is recommended for large vessels where the free half channel width is less than 75 meters since the final integrity check is performed by the monitor station which is computing an

overdetermined position solution with all satellites for which corrections are being broadcast. Additionally, such a receiver provides a much higher degree of protection from shading and pseudorange anomalies as well as having the capability to download the navigation messages for all satellites in view as they are broadcast. All other vessels should employ receivers with at least five parallel continuously tracking channels.

3. The user equipment suite should be able to combine the UDRE values with localized error factors such as user receiver noise, interference, multipath, HDOP, and PRC latency in order to provide a confidence level about the user's displayed position.
 - a. Protection Limit: The protection limit for the overdetermined solution computed at the monitor shall be 12.6 meters. This corresponds to an 8 meter 2drms level of performance at the broadcast site. The integrity monitor will utilize the broadcast UDRE values to weight the pseudoranges in computing the overdetermined solution. The known position of the IM is not included in the overdetermined solution which it computes.
 - b. Time to Alarm: The time from when a protection limit is exceeded to when the user equipment suite/user is alarmed by the broadcast shall be less than 2 seconds for 200bps transmission rates, 4 seconds for 100bps transmission rates, and 8 seconds for 50bps transmission rates. This time includes the length of the longest possible message and the header of the following message. The use of the Type 9 message as the exclusive PRC message results in these low time to alarm values. The user equipment suite would only have to alert the user for pseudorange level alarms if an adequate constellation no longer exists at that time for that user location. See 4E for a discussion of the alarm mechanisms.

D. RELIABILITY

1. To the user the reliability of the system connotes that if the system was useable at the beginning of the mission segment (maneuver) what are the chances that the service will not fail over the course of the subject segment (maneuver). The reliability for a given coverage area (which can be a subset of an AOC) is given in Table 4. Though these values were determined on the basis of an expanded operational envelope, it has been determined that the initial operational system can universally meet these specifications.

TABLE 4. SYSTEM RELIABILITY SPECIFICATIONS

MANEUVER CATEGORY	RELIABILITY (OUTAGES/Mhr)
<140 sec	2000
140 to 280 sec	1000
280 to 560 sec	500

E. ALARM MECHANISMS

1. Pseudorange alarms are broadcast by the setting of the PRC(t0) Field (bits 9 through 24) to a value of binary 1000 0000 0000 0000 along with the setting of the RRC Field (bits 17 through 24) to a value of 1000 0000. Should the user equipment suite detect either one of these settings it should immediately stop applying any PRC derived information for that satellite until the alarm condition ends.
2. Positional alarms will occur when either an insufficient constellation exists due to the lack of healthy pseudoranges or the failure of the pseudorange weighting or monitoring functions - as it acts an additional check. As discussed in Section 2C this condition is indicated by the message header which allows the broadcast of an alarm without breaking frame synchronization.
3. The unmonitored condition alarm is also indicated by the message header and will generally occur for durations of only several minutes. During this time the redundant monitor is switched in and performs an initial assessment of the broadcast before the status of the system returns to the monitored condition. As co-located reference stations usually maintain a time base to within 15ns of each other, the monitor receiver may be able verify the broadcast health status for the new reference station in a matter of seconds. Only when a monitor fails and the redundant monitor can not be switched in will unmonitored conditions last for prolonged periods of time.

F. APPLICATION OF INTEGRITY MESSAGES

1. If either an unhealthy or unmonitored condition exists as indicated by the header of any message it should be conveyed to the user by a textual message displayed by the user equipment suite. Additionally, unhealthy or unmonitored conditions should cause a visual alarm to activate. If a marine radiobeacon is utilized beyond 300 statute miles the user equipment suite shall display this condition in order to indicate that additional error components are present, attributable to spatial

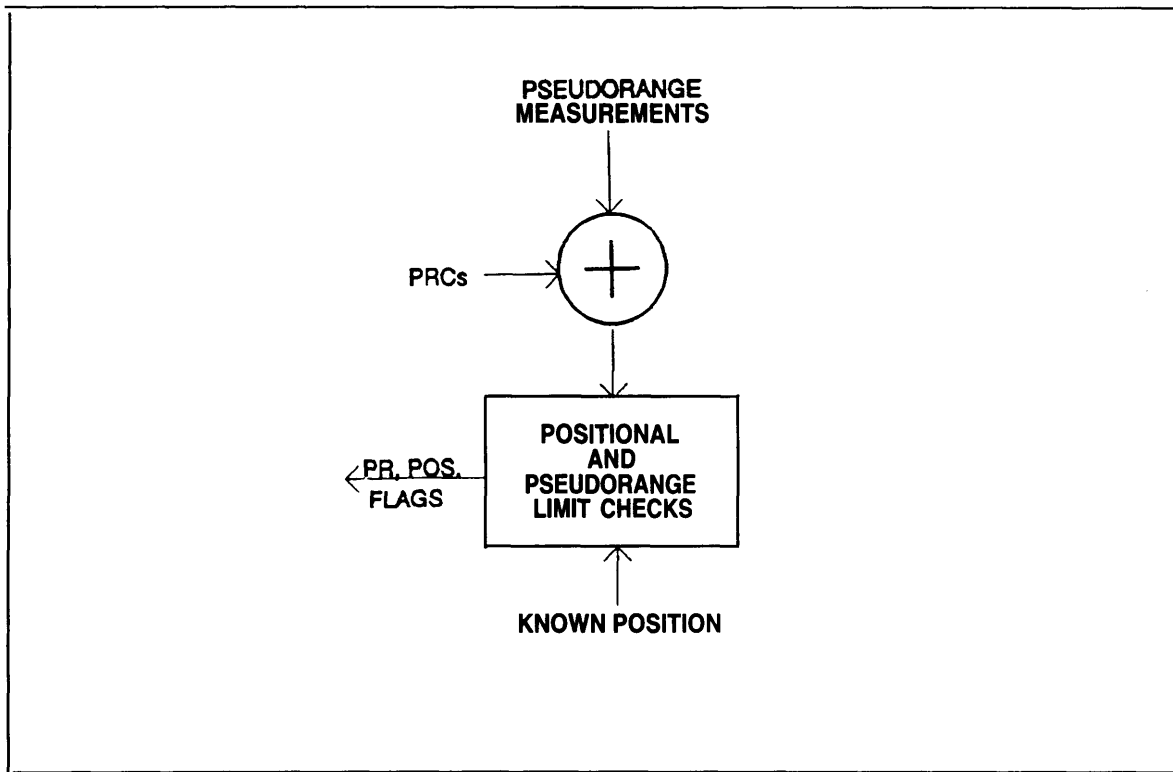

FIGURE 9.- INTEGRIH MONITOR PROCESS

decorrelation and increased correction latency (which is due to a less robust broadcast channel), and are not accounted for. The USP of the broadcast signal beyond its specified range is further discussed in Section 6B.

CHAPTER 5. COVERAGE

A. POLICY

1. The USCG DGPS Navigation Service is designed to provide coverage at the specified levels for all "Harbor and Harbor Approach Areas" and other "Critical Waterways" for which the U.S. Coast Guard provides aids to navigation. Due to the omni-directional nature of the broadcasts, and that a high power radiobeacon may cover more than one harbor, coverage often extends into additional areas. As a result, complete coverage of the coast line of the continental United States is provided out to 20nmi. It is expected that in the near future this coverage will be extended to cover the complete CONUS coastal navigation zone which extends out to 50nmi. Though the accuracy of DGPS is much higher than needed in the coastal region, its integrity enhancement of GPS is what is most needed. Additional areas which receive this incidental, but fully specification compliant coverage are all waters of the Great Lakes (with the exception of portions of the Georgian Bay on Lake Huron) and a considerable segment of the lower St. Lawrence Seaway. Coverage for the Western Rivers (Mississippi, Missouri, Ohio, and Illinois) and Northern Alaska is not planned in the initial system but is under consideration for phase in at a later time, as is coverage of the complete EEZ (exclusive economic zone) and the U.S. portion of the St. Lawrence Seaway. The network of radiobeacons which comprise tService will provide considerable portions of most areas with redundant which require the movement of large vessels in severely constricted waterways will be provided with fully redundant coverage.

B. DIAGRAMS

1. Separate coverage diagrams are provided in Enclosure 2 for the following regions:
 - Atlantic & Gulf Coasts
 - Pacific Coast
 - Great Lakes
 - Alaska
 - Hawaii
 - Puerto Rico
2. These diagrams are based upon the broadcast site listings at publication time and the content of the current Type 7 message is the only true representation of the coverage which is currently being provided. Coverage over land areas will be verified only for areas in which broadcasts are required to traverse land in order to cover a designated waterway.

C. BROADCAST SITE LISTINGS

1. Broadcast site listings are contained in Enclosure 1, and are partitioned in the same manor as the coverage diagrams. As was stated for the Coverage Diagrams, the current Type 7 Message, and not the Coverage Diagrams nor the Broadcast Site Listings, represent the coverage which is presently being provided.

D. ASSIGNMENT OF REFERENCE STATION ID NUMBERS

1. Enclosure 1 contains a cross reference for the reference station ID Numbers and Broadcast Sites. Sites which are contained in a given region will fall within the following ranges of id numbers:

Great Lakes	800 - 829
Atlantic, Gulf Coasts & Puerto Rico	830 - 869
Pacific Coast, Alaska & Hawaii	870 - 910
Western Rivers*	911 - 950

*set aside for possible expansion

E. INFORMATION UPDATES

1. The latest updated information pertaining to the DGPS Service is available through the GPS Information Center (GPSIC). This is a service which is provided by the USCG for the users of the Global Positioning System. The GPSIC maintains a twenty-four hour watch and can be contacted at telephone # (703) 313-5900. Information on the DGPS Navigation Service which is available includes:
 - Current System Status
 - Coverage Diagrams
 - Broadcast Site Listings
 - Current Plans/General Information etc.
2. All information which is provided can be downloaded from a computer bulletin board. For the coverage diagrams, the Tagged Image File (TIF) format will be utilized. The GPSIC computer bulletin board may be accessed by dialing (703) 313-5910 for modem speeds of 300 -14,400 bps. The protocol is asynchronous with 8 data bits, 1 stop bit, and no parity. A wide range of DGPS and GPS information is available ranging from DGPS Broadcast Site Listings to GPS precise ephemeris data. Current USCG publications which are of interest to a large user segment are also available on the bulletin board.
3. RTCM Special Committee No.104 (Version 2.1) "Recommended Standards for Differential NAVSTAR GPS Service" can be purchased from the RTCM by telephoning (202) 639-4006 or by writing:

Radio Technical Commission for Maritime Services
Post Office Box 19087
Washington, DC 20036

CHAPTER 6. MARINE RADIOBEACON SELECTION

A. GENERAL

1. In actual use the beacon selection scenarios which the user may encounter are:
 - One satisfactory broadcast is available
 - Two or more satisfactory broadcasts are available
 - No satisfactory broadcasts are available
2. In the first scenario the choice is rather simple as the sole satisfactory beacon is chosen and its health and various parameters are constantly monitored by the user equipment suite as discussed in 4.E. The criteria for a satisfactory broadcast is delineated in 6.B. The second scenario occurs in varying portions of all specified AOC's. Due to the topology of the network, the user should select the closest satisfactory broadcast which is within its advertised range. In a limited number of locations where several broadcasts are available, the closest one may not necessarily be the one with the highest received power. In general, the additional spatial decorrelation will exceed the benefits associated with a slightly higher signal strength. Additionally, as several short range higher data rate transmissions are deployed in various critical areas the choice of the closest beacon falls in line with the choice of the beacon with the highest data rate.
3. The third scenario, that is when no satisfactory beacons are available, requires special attention. Due to various circumstances there may be rare times when a user may be in this predicament. This use may not only be elective, if due to the sudden onset of low visibility conditions the vessel may need to rely on the existing coverage until it can be safely anchored. The user equipment suite can estimate a position error from the UDRE and localized information - the mariner needs to weigh this estimate relative to the situation at hand.
4. Due to the high level of attenuation across coverage areas (especially land and fresh water) and the possible existence of significant levels of man made noise the signal quality at the user can be much different than at a monitor. Noise due to atmospheric activity just to the north of a coverage area can be attenuated more than 30dB before reaching the southern portion of the coverage area. In conclusion, only the user equipment suite can truly act as the coverage monitor for the users location.

B. SATISFACTORY BROADCAST CLASSIFICATION

1. A satisfactory broadcast is one which is classified as healthy, is presently monitored, the PRC time out limit for at least four satellites has not been reached, and the beacon id number checks out against the beacon almanac. The user need not be within the advertised range of the broadcast for it to be satisfactory.

C. EXTENDED BROADCAST USAGE

1. If no closer satisfactory beacons can be utilized a satisfactory beacon can be used beyond its advertised range if the user is within 300 statute miles of the broadcast site. The user should exercise extra caution in this situation since user reliability is reduced if the primary beacon for a subject waterway is unavailable.

D. PRC TIME OUT LIMIT

1. No pseudorange correction may be applied to the user's navigation solution if its age exceeds 30 seconds. When Type 9-3 Messages are broadcast at 100bps for nine satellites the user would have to miss four consecutive updates until the time out limit is reached for a given pseudorange. This would require the user to miss four consecutive updates for five of the nine satellites before having to exit the differential navigation mode. Note that for the Type 9-1 Message all pseudoranges are fully decoupled in that each message only contains the correction for one satellite. User equipment suites with an integrated inertial sensor have the potential to coast through such periods if they did occur.

E. SUMMARY

1. For a user at any given location all DGPS Radiobeacons fall into one of the following three classifications:
 - Satisfactory and within advertised range
 - Satisfactory and within 300mi
 - Unmonitored, within PRC time out limit, and 300mi
2. The user equipment suite should always initially select the closest satisfactory beacon which is within its advertised range. If the only choice is an unmonitored broadcast then the user should only use the subject broadcast with an enhanced level of caution. When switching broadcasts the user equipment suite should discard all pseudorange corrections from the previous broadcast before utilizing any pseudorange corrections from the new broadcast.

APPENDIX 1. GLOSSARY

A. ACRONYMS

AOC	Area of Coverage
bps	bits per second
CONUS	Continental United States
dB	decibel
DGPS	Differential Global Positioning System
drms	Distance Root Mean Square
EEZ	Exclusive Economic Zone
GPS	Global Positioning System
HDOP	Horizontal Dilution of Precision
Hz	Hertz
IM	Integrity Monitor
IOD	Issue of Data
KHz	Kilo-Hertz
m	meter
M	Million
MF	Medium Frequency
MSK	Minimum Shift Keying
mV	milli-Volt
NAD 83	North American Datum of 1983
nm	Nautical Mile
ns	nano-second
PRC	Pseudorange Correction
RBn	Radiobeacon
RDF	Radio Direction Finder
RRC	Range Rate Correction
RS	Reference Station
RTCA	Radio Technical Commission for Aeronautical Services
RTCM	Radio Technical Commission for Maritime Services
SIR	Signal to Interference Ratio
SNR	Signal to Noise Ratio
SPS	Standard Positioning Service
SV	Space Vehicle
UDRE	User Differential Range Error
uV	Micro-Volt

B. DEFINITIONS

Advertised Range: The range for which a broadcast provides the minimum specified field strength for an AOC in which it is the primary broadcast.

Area of Coverage: A designated geographic area which contains one or more navigable waterways which are provided with coverage by the DGPS Navigation Service.

Availability-broadcast: The percentage of time in a one month period during which a broadcast provides a healthy signal at a specified output power level.

Availability-signal: The percentage of time in a one month period in which a healthy signal is available in a given area from at least one broadcast which exceeds the minimum specified field strength.

Availability-user: The percentage of time in a one month period in which a signal is available to a user at any given part of an AOC which allows the position accuracy specification to be met.

Data Rate: The number of information bits per second which are broadcast.

Datum: A geodetic coordinate system which is specific to a given geographical region.

2DRMS: A specific statistical measure characterizing the scatter contained in a set of randomly varying measurements spread out on a flat plane. As used in this document, it is the radius of a circle on the horizontal plane which contains at least 95 percent of all possible fixes that result at any one place.

Field Strength: The peak field intensity of each tone which comprises the broadcast MSK Signal as measured at five feet above ground level.

Free Half Channel Width: One half of the channel width minus the vessel's half beam width.

Geodetic Monument-B Order: A surveyed position which was derived from baselines which are accurate to one part a million.

Integrity: The ability of a system to provide timely warnings to users when it should not be used for navigation.

Latency: The difference between the time at which the first bit of a given message is broadcast and the time tag in the header of the pseudorange correction messages. The time tag in the message header is the Z-Count which is closest to the time of last measurement upon which a correction is based. Latency is specified as an average in order to take into account the difference between the Z-Count and the time of measurement which can be up to 0.6 seconds.

Navigation Service: A service which provides information which allows position and possibly velocity determination while maintaining a high degree of integrity.

Primary Beacon: The closest beacon to a given user who is within the advertised range for that beacon.

Primary Broadcast: Same as Primary Beacon

Protection Limit: The user position error which shall not be exceeded without the broadcast of an alarm.

Protection Ratio: The ratio of a wanted to an interfering carrier.

Reference Receiver: A component of the reference station which measures the pseudoranges, computes pseudorange corrections, determines the UDRE values, and formats the broadcast messages.

Reference Station: An integrated Reference Receiver and MSK Modulator.

Reliability-broadcast: The probability that a given broadcast will remain healthy and provide the specified signal strength for a specified period of time (mission segment).

Reliability-signal: The probability that at least one broadcast which covers a given area will remain healthy and provide the minimum specified signal strength for a specified period of time (mission segment).

Reliability-user: The probability that a user will be able to continue to achieve the specified accuracy level for a specified period of time (mission segment) regardless of all operating conditions.

Sequencing Receiver: A DGPS Receiver which uses a given channel to multiplex between two or more satellites in order to measure pseudoranges and receive navigation messages.

Time to Alarm: The maximum allowable time between the appearance of an error outside the protection limit at the integrity monitor and the broadcast of the alarm.

Transmission Rate: The total number of bits per second which are broadcast.

UDRE: A one sigma estimate of the pseudorange correction error due to ambient noise and residual multipath.

Unhealthy: Unable to operate within tolerance.

Unmonitored: Not monitored by an integrity monitor.

Enclosure (1) to COMDTINST M16577.1

ENCLOSURE (1) TO COMDTINST M16577.1
LISTING OF BROADCAST SITES

Enclosure (1) to COMDTINST M16577.1

LEGEND:

1 : Approximate site location, actual site may be located in the general area

VTS : Utilized for Vessel Tracking by the USCG Vessel Traffic Service

(*site name*) : Name which site may be otherwise known

[*site name*] : Possible site for future use / added redundancy

NOTES:

1. In the following tables broadcast ranges are given in statute miles for the Great Lakes Region and nautical miles elsewhere, note that in the Type 7 Message all ranges are given in nautical miles.

2. Transmission Rates and Frequencies may be changed within the parameters of this document, advance notice will be given through a Local Notice To Mariners.

**United States Coast Guard DGPS Site Information
Atlantic and Gulf Coasts**

15 Apr 1996

Field		Frequency	Trans	Latitude	Longitude	Range	Strength	Ref
Broadcast	Radiobeacon							
Ref	Site		Rate					Sta A
Sta B	Sta B	(Khz)	(BPS)	(N)	(W)	(NM)	(uV)	ID
ID	ID							
NAS Brunswick, ME 001	800	316	100	43 53.40	69 56.80	115	75	000
Portsmouth Harbor, NH 003	801	288	100	43 04.30	70 42.60	100	75	002
Chatham, MA 005	802	325	200	41 40.30	69 57.00	95	100	004
Montauk Point, NY 007	803	293	100	41 04.00	71 51.60	130	75	006
Sandy Hook, NJ 009	804	286	200	40 28.30	74 00.70	100	100	008
Cape Henlopen, DE 011	805	298	200	38 46.60	75 05.30	180	75	010
Cape Henry, VA 013	806	289	100	36 55.60	76 00.40	130	75	012
Fort Macon, NC 015	807	294	100	34 41.80	76 41.00	130	75	014
Charleston, SC 017	808	298	100	32 45.50	79 50.60	150	75	016
Cape Canaveral, FL 019	809	289	100	28 27.60	80 32.60	200	75	018
Miami, FL 021	810	322	100	25 44.00	80 09.60	75	75	020
Key West, FL 023	811	286	100			110	75	022
Egmont Key, FL 025	812	312	200	27 36.00	82 45.60	210	75	024
Puerto Rico 035	817	295	100	18 27.80	67 04.00	125	75	034
Mobile Point, AL 027	813	300	100	30 13.70	88 01.40	170	75	026
English Turn, LA 029	814	293	200	29 52.70	89 56.50	170	100	028
Galveston, TX 031	815	296	100	29 19.80	94 44.20	180	75	030
Aransas Pass, TX 033	816	304	100	27 50.30	97 03.50	180	75	032

Enclosure (2) to COMDTINST M16577.1

**ENCLOSURE (2) TO COMDTINST M16577.1
COVERAGE DIAGRAMS**

Note: The elliptical areas represent the advertised ranges and the shaded areas represent the predicted minimum specified field intensity contours up to the advertised range.

Great Lakes Region

Field Broadcast		Frequency	Trans	Latitude	Longitude	Range	Strength	Ref Sta	
A Ref Sta	B Radiobeacon							Ref	Sta
Site ID	ID	(Khz)	Rate (BPS)	(N)	(W)	(NM)	(uV)	ID	
Wisconsin Point, WI 101	830	296	100	46 42.30	92 00.90	40	75	100	
Upper Keweenaw, WI 103	831	298	100	47 13.60	88 37.40	130	75	102	
Sturgeon Bay, WI 105	832	322	100	44 47.70	87 18.90	110	75	104	
Milwaukee, WI 107	833	297	100	43 00.10	87 53.30	140	75	106	
Whitefish Point, MI 109	834	318	100	46 46.30	84 57.50	80	75	108	
Neebish Island, MI 111	835	309	200	46 19.30	84 09.00	60	100	110	
Cheboygan, MI 113	836	292	200	45 39.20	84 27.90	110	100	112	
Saginaw Bay, MI 115	837	301	100	43 37.70	83 50.30	85	75	114	
Detroit, MI 117	838	319	200	42 17.80	83 05.70	100	100	116	
Youngstown, NY 119	839	322	100	43 13.90	78 58.20	150	75	118	

Inland Rivers Region**

Broadcast		Frequency	Trans	Latitude	Longitude	Range	Strength	Field Ref Sta	
A Ref Sta	B Radiobeacon							Ref	Sta
Site ID	ID	(Khz)	Rate (BPS)	(N)	(W)	(NM)	(uV)	ID	
Vicksburg, MS 151	860	313	200	32 19.90	90 55.20	115	100	150	
Memphis, TN 153	861	310	200	35 27.90	90 12.30	115	100	152	
St Louis, MO 155	862	322	200	38 36.70	89 45.50	115	100	154	
Rock Island, IA 157	863	311	200	42 00.50	90 14.00	150	100	156	
St. Paul, MN 159	864	317	200	44 18.20	91 54.20	150	100	158	
Millers Ferry, AL 161	865	320	200	32 05.40	87 23.50	150	100	160	
Sallisaw, OK 163	866	299	200	35 22.00	94 49.00	100	100	162	
Kansas City, MO 165	867	305	200	39 07.07	95 24.88	100	100	164	

* Great Lakes and Western Rivers DGPS sites indicate radiobeacon ranges in statute miles, all others are in nautical miles.

** Future Plans are to add an additional eight sites to the Inland Rivers Region.

Alaska, Pacific Coast, and Hawaii

Broadcast		Frequency	Trans	Latitude	Longitude	Range	Strength	Field	
A Ref Sta	B Radiobeacon							Ref Sta	ID
Site			Rate						
ID	ID	(Khz)	(BPS)	(N)	(W)	(NM)	(uV)		
Cold Bay, AK		289	100	55 05.50	162 31.90	180	75	296	
297	898								
Kodiak, AK		313	100	57 37.10	152 11.60	180	75	294	
295	897								
Kenai, AK		310	100	60 40.10	151 21.00	170	75	292	
293	896								
Potato Point, AK		298	100	61 03.00	146 42.00	100	75	290	
291	895								
Cape Hinchinbrook, AK		292	100	60 14.30	146 38.80	120	75	288	
289	894								
Gustavus, AK		288	100	58 25.10	135 41.80	170	75	284	
285	892								
Annette Island, AK		323	100	55 04.10	131 36.00	170	75	278	
279	889								
Whidbey Island, WA		302	100	48 18.80	122 41.80	90	75	276	
277	888								
Robinson Point, WA		323	200	47 23.30	122 22.50	60	100	274	
275	887								
Fort Stevens, OR		287	100	46 12.30	123 57.40	180	75	272	
273	886								
Cape Mendocino, CA		292	100	40 26.40	124 24.40	180	75	270	
271	885								
Point Blunt, CA		310	200	37 51.20	122 25.10	60	100	268	
269	884								
Pigeon Point, CA		287	100	37 11.20	122 23.40	180	75	266	
267	883								
Point Arguello, CA		321	100	34 34.70	120 38.60	180	75	264	
265	882								
Point Loma, CA		302	100	32 39.90	117 14.60	180	75	262	
263	881								
Kokole Point, HI		300	200	21 59.00	159 45.50	300	75	260	
261	880								
Upolu Point, HI		285	100	20 14.80	155 53.00	170	75	258	
259	879								

Enclosure (2) to COMDTINST M165771.A

US COAST GUARD DGPS COVERAGE OF THE ATLANTIC AND GULF COASTS

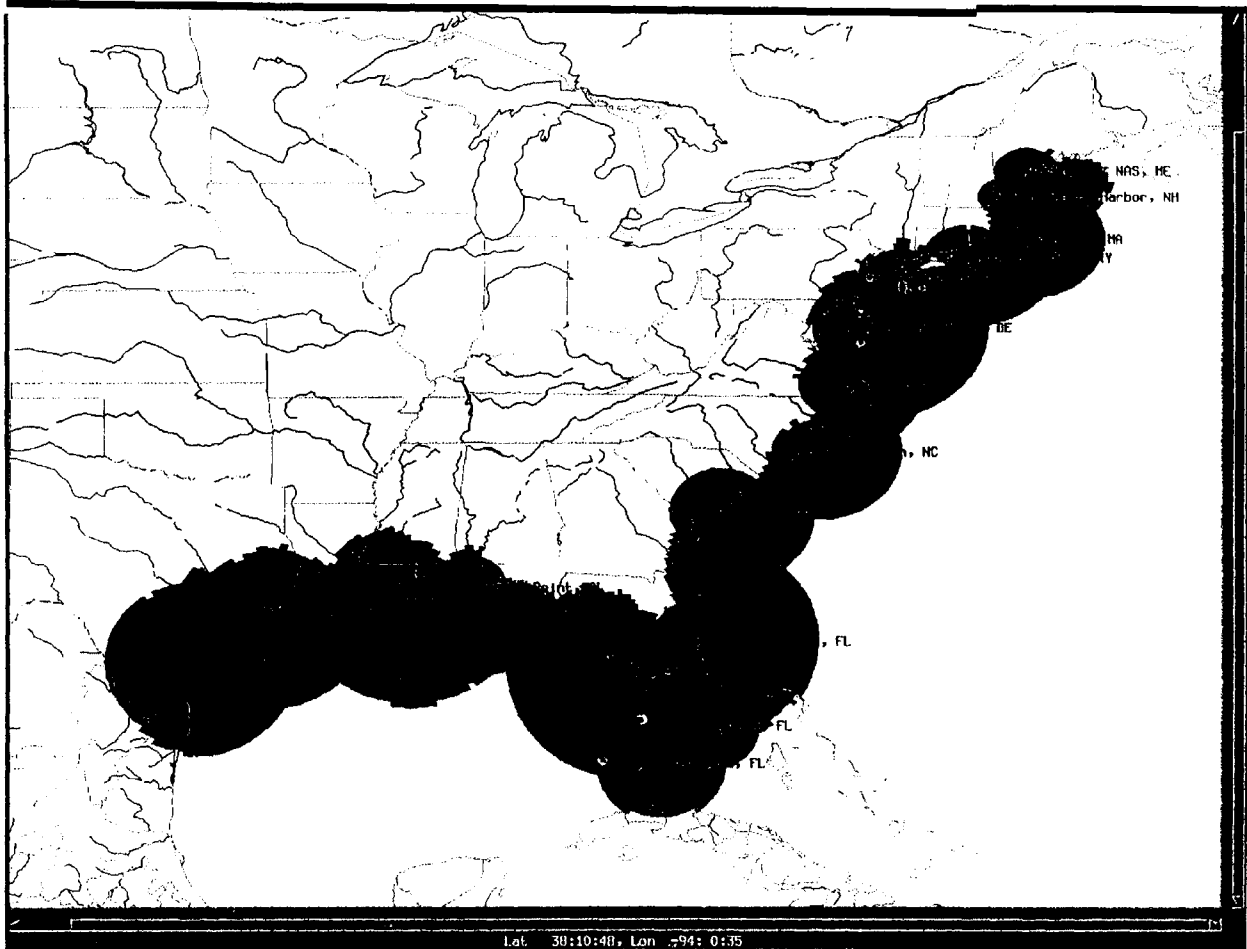

US COAST GUARD DGPS COVERAGE OF PUERTO RICO

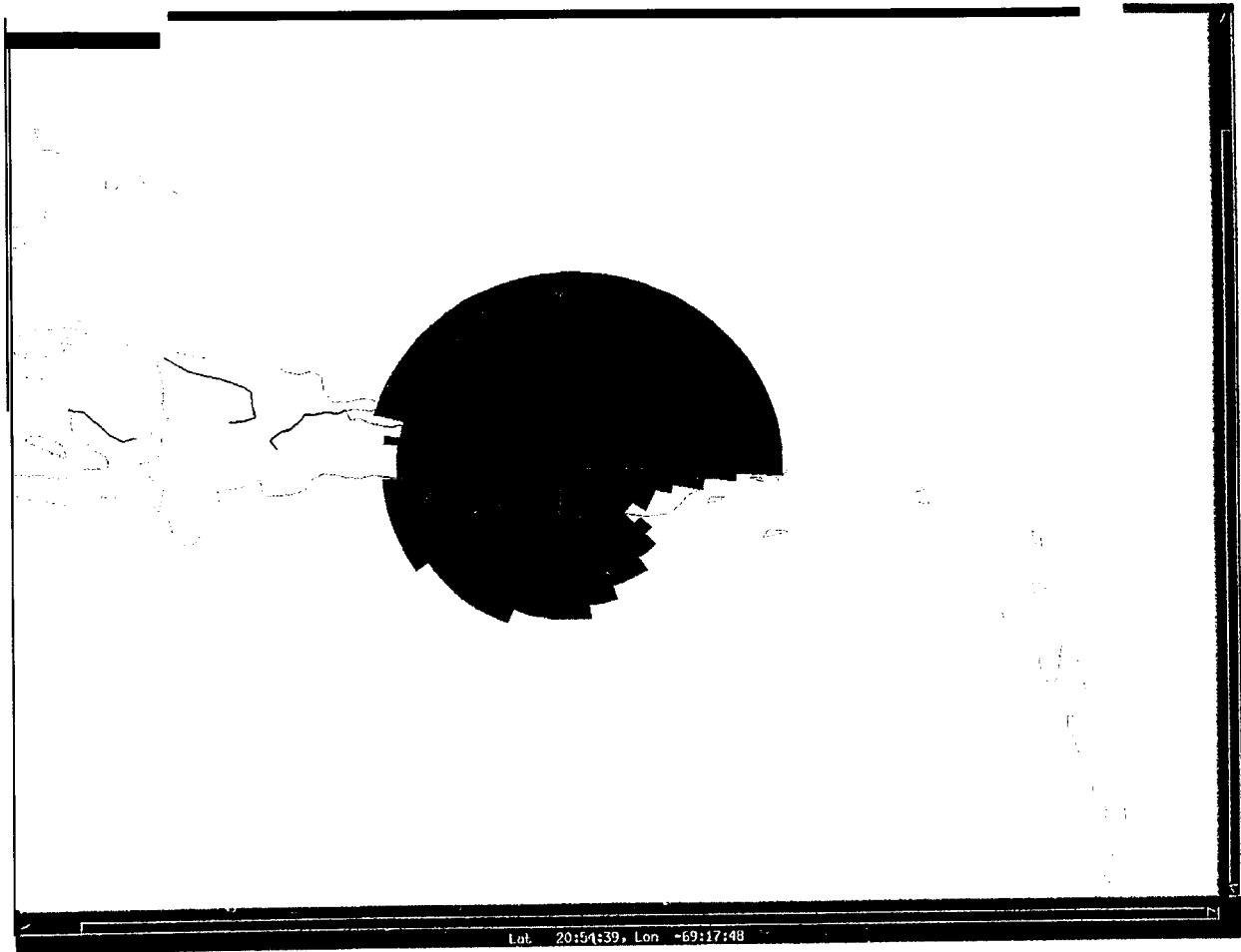

US COAST GUARD DGPS COVERAGE OF THE GREAT LAKES REGION

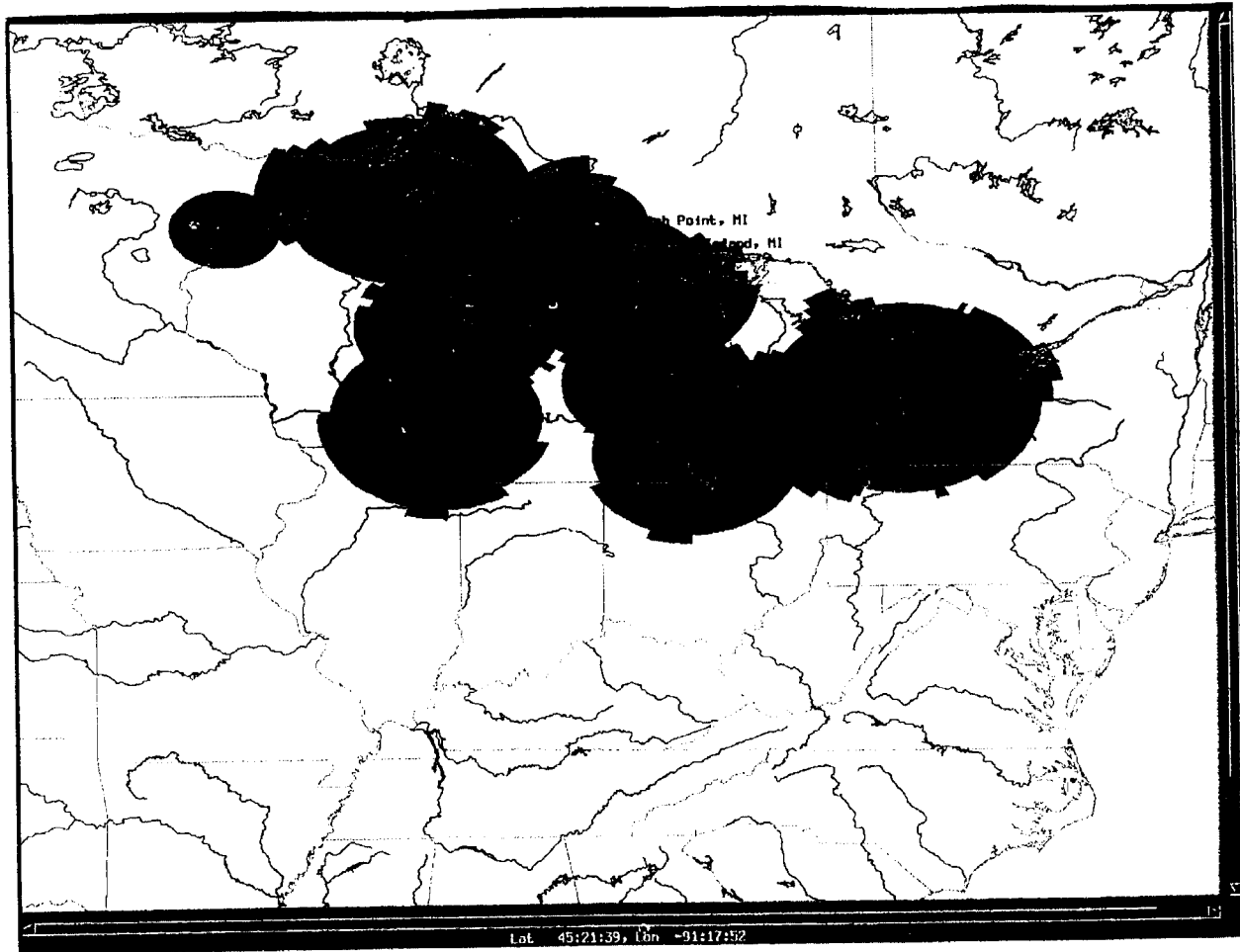

US COAST GUARD DGPS COVERAGE OF THE INLAND RIVERS REGION



Enclosure (2) to COMDTINST M16577.1A

US COAST GUARD DGPS COVERAGE OF THE PACIFIC COAST

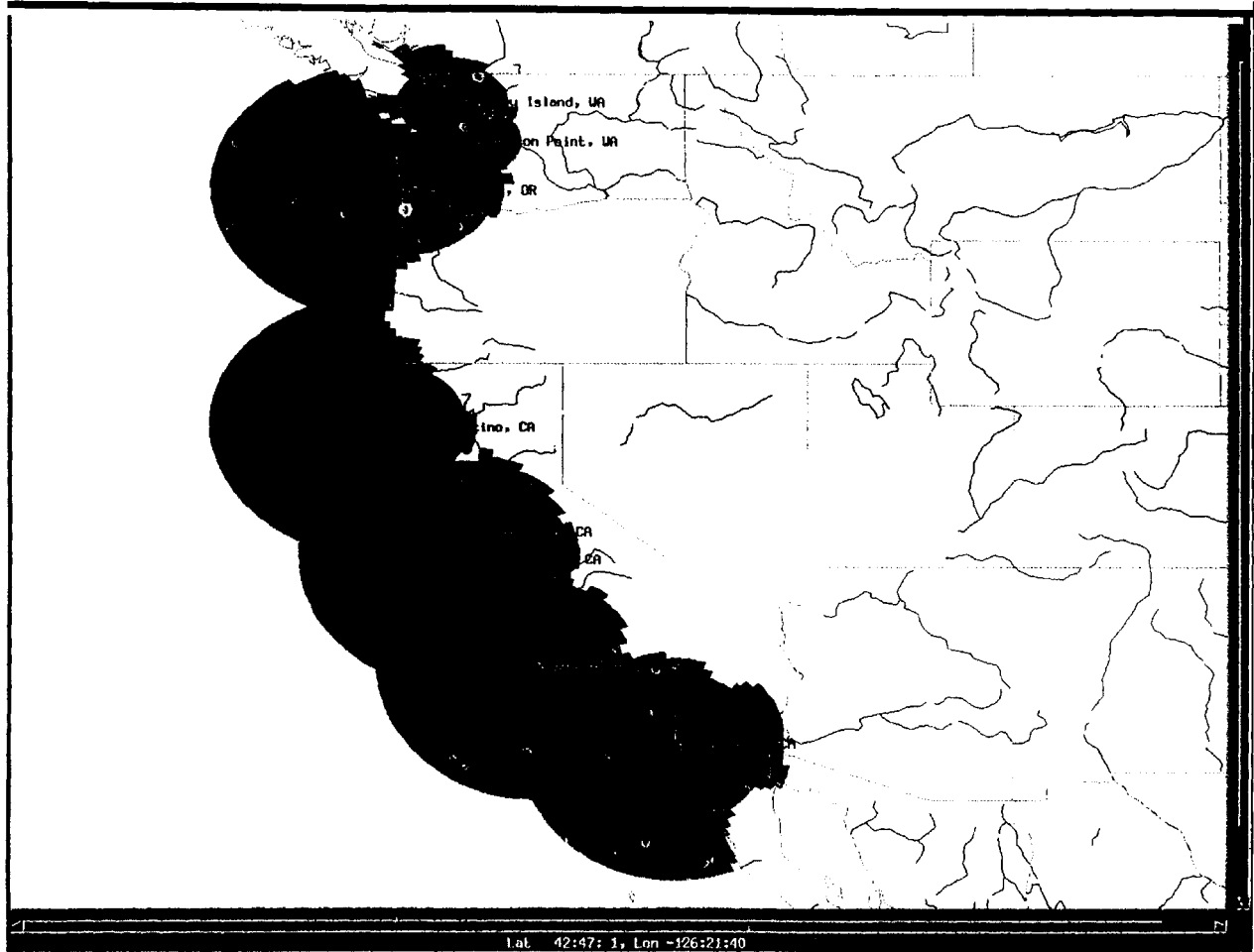

US COAST GUARD DGPS COVERAGE OF ALASKA



Enclosure (2) to COMDTINST M16577.1A

US COAST GUARD DGPS COVERAGE OF HAWAII

